

ABB industrial drives

Application guide

ACS800-01/04/11/31/104/104LC Safe torque off function
(+Q967)

efesotomasyon.com



efesotomasyon.com

Power and productivity
for a better world™



Application guide

ACS800-01/04/11/31/104/104LC Safe torque off function
(+Q967)

efesotomasyon.com

Table of contents



3. Installation



4. Start-up and validation



Table of contents

efesotomasyon.com

1. Basics

Option codes (plus codes)	8
---------------------------------	---

2. Program features, settings and diagnostics

Operation of the STO function and its diagnostics function	9
STO function activation and indication delays	10
Module delays only	10
Delays with typical STO safety relay	10

3. Installation

Example wiring diagrams	11
Without safety relay	12
Frame sizes R2 to R6	12
Frame sizes R2i to R4i	12
Frame size R5i	13
Frame size R7i	13
Frame size R8i	14
Liquid-cooled modules of frame sizes R7i and R8i	14
With safety relay	15
Frame sizes R2 to R6	15
Frame sizes R7 and R8	15
Frame sizes R2i to R4i	16
Frame size R5i	16
Frame size R7i	17
Frame size R8i	17

4. Start-up and validation

Validating the operation of a safety function	19
Authorized person	19
Acceptance test reports	19
Start-up checklist	20

5. Maintenance, fault tracing and diagnostics

Maintenance	21
Warning messages generated by the drive	21
Fault messages generated by the drive	22

6. Technical data

STO components	23
ASTO-11/21 board	23
ASTO board according to frame size of the module	23
STO safety relay type	24



Push-button to be used with emergency stop	24
STO switch to be used with prevention of unexpected start-up function implemented with STO	24
STO data related to safety standards (safety relay not included)	24
Frame size R2/R2i	24
Frame size R3/R3i	24
Frame size R4/R4i	25
Frame size R5/R5i	25
Frame size R6	25
Frame size R7/R7i/R8/R8i	25
Multiples of frame size R8i	25
Frame size 2×R8i	25
Frame size 3×R8i	25
Frame size 4×R8i	25
Frame size 5×R8i	26
Frame size 6×R8i	26
Frame size 7×R8i	26
Frame size 8×R8i	26
Frame size 9×R8i	26
Frame size 10×R8i	26
Frame size 11×R8i	26
Frame size 12×R8i	26
Abbreviations	27
TÜV certificate	28

Further information

Product and service inquiries	29
Product training	29
Providing feedback on ABB Drives manuals	29
Document library on the Internet	29





Basics

The drive supports the Safe torque off (STO) function according to standards EN 61800-5-2:2007; EN ISO 13849-1:2008, IEC 61508 and EN 62061:2005. The function also corresponds to an uncontrolled stop in accordance with category 0 of EN 60204-1 and prevention of unexpected start-up of EN 1037.

The STO may be used where power removal is required to prevent an unexpected start. The function disables the control voltage of the power semiconductors of the drive output stage, thus preventing the inverter from generating the voltage required to rotate the motor (see diagram below). By using this function, short-time operations (like cleaning) and/or maintenance work on non-electrical parts of the machinery can be performed without switching off the power supply to the drive.

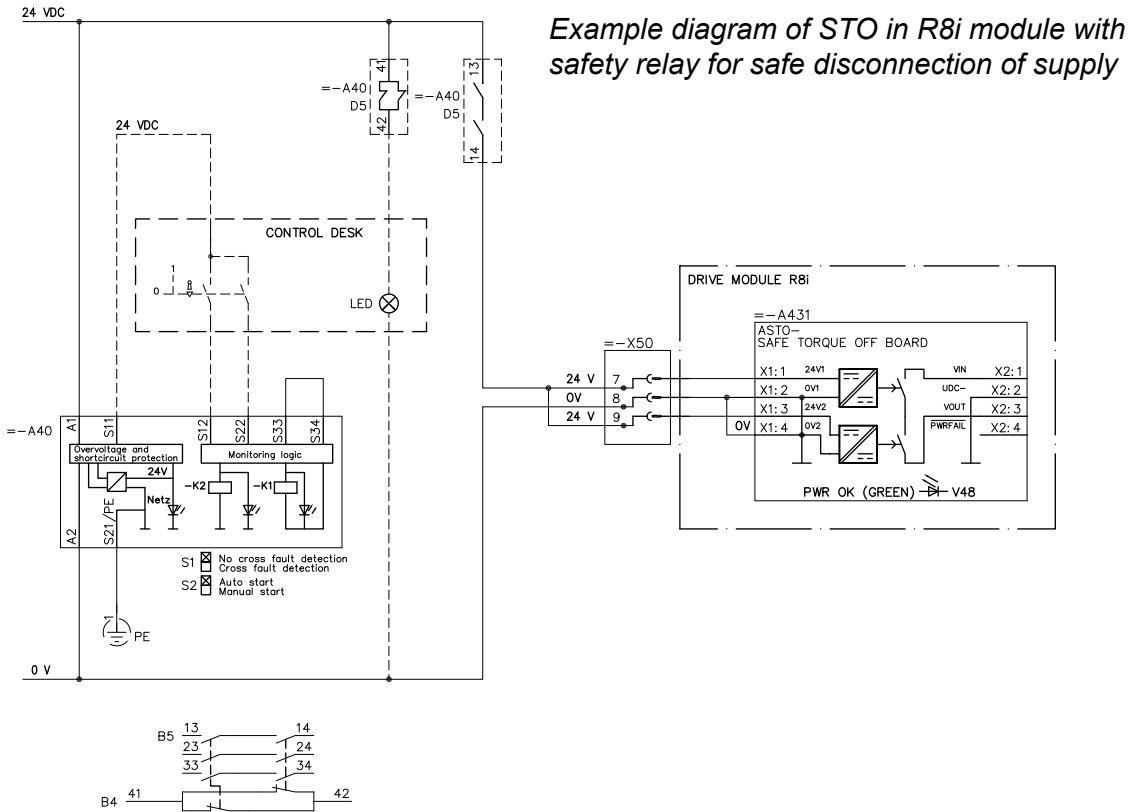

WARNING! The Safe torque off function does not disconnect the voltage of the main and auxiliary circuits from the drive. Therefore maintenance work on electrical parts of the drive or the motor can only be carried out after isolating the drive system from the main supply.

Note: The Safe torque off function can be used for stopping the drive in emergency stop situations. In the normal operating mode, use the Stop command instead. If a running drive is stopped by using the function, the drive will trip and stop by coasting. If this is not acceptable, e.g. causes danger, the drive and machinery must be stopped using the appropriate stopping mode before using this function.

Note concerning permanent magnet motor drives in case of a multiple IGBT power semiconductor failure: In spite of the activation of the Safe torque off function, the drive system can produce an alignment torque which maximally rotates the motor shaft by $180/p$ degrees. p denotes the pole pair number.

Option codes (plus codes)

Options codes related to safety features are listed below.

Safety features	
Q963	Emergency Stop, stop cat. 0 without opening the main contactor/breaker
Q964	Emergency Stop, stop cat. 1 without opening the main contactor/breaker, SS1
Q967	STO Safe torque off (in module and cabinet)
Q968	Safe torque off with safety relay



Program features, settings and diagnostics

Operation of the STO function and its diagnostics function

When both STO inputs are energized, the STO function is in the standby state and the drive operates normally. If the STO inputs are de-energized, the STO function awakes, stops the drive and disables start. Start is possible only after the STO inputs have been energized, and any faults of the drive have been reset.

The table below describes the operation of the STO function in detail depending on:

- status of the STO inputs
- the fault or warning START INHIBI (see also chapter *Maintenance, fault tracing and diagnostics*).

Status of STO inputs	When drive is	How the STO function operates	START INHIBI indication
De-energized	running	Awakes and trips the drive.	Fault
	stopped	Awakes and disables start.	Warning
One energized, other de-energized	running	Awakes and trips the drive.	Fault
	stopped	Awakes and disables start.	Warning
Energized	running or stopped	STO is on standby. Drive operates normally.	-

STO function activation and indication delays

■ Module delays only

STO activation and indication delays	Typical delay	Maximum delay
STO activation delay ¹⁾	2 ms	20 ms
STO indication delay ²⁾	1,5 ms	-

¹⁾ STO activation delay = delay between de-energizing the STO input and switching off the drive output bridge

²⁾ STO indication delay = delay between de-energizing the STO input and indication of STO input de-energization

■ Delays with typical STO safety relay

STO activation and indication delays	Typical delay	Maximum delay
STO activation delay ³⁾	52 ms	70 ms
STO indication delay ⁴⁾	51,5 ms	-

³⁾ STO activation delay = delay between de-energizing the STO relay and switching off the drive output bridge

⁴⁾ STO indication delay = delay between de-energizing the STO relay and indication of STO input de-energization

A large blue square with rounded corners containing the white number '3' in the center.

Installation



WARNING! The supply voltage for ASTO-11C and ASTO-21C board is 24 V DC. If the board is supplied with 230 V or 115 V, the board is damaged and it needs to be replaced.

Example wiring diagrams



WARNING! For connecting the ASTO board and the module, use only wire kits delivered by ABB.

Connect the cables as shown in the diagram below. For more information on the components, see chapter [Technical data](#).



12 Installation

■ Without safety relay

Frame sizes R2 to R6

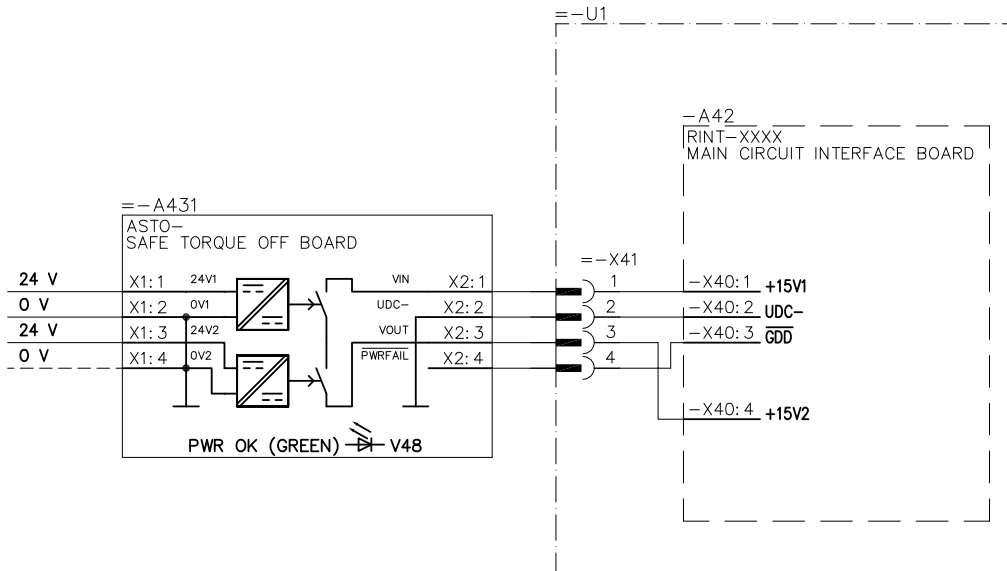

3AUA0000072542

Frame sizes R2i to R4i

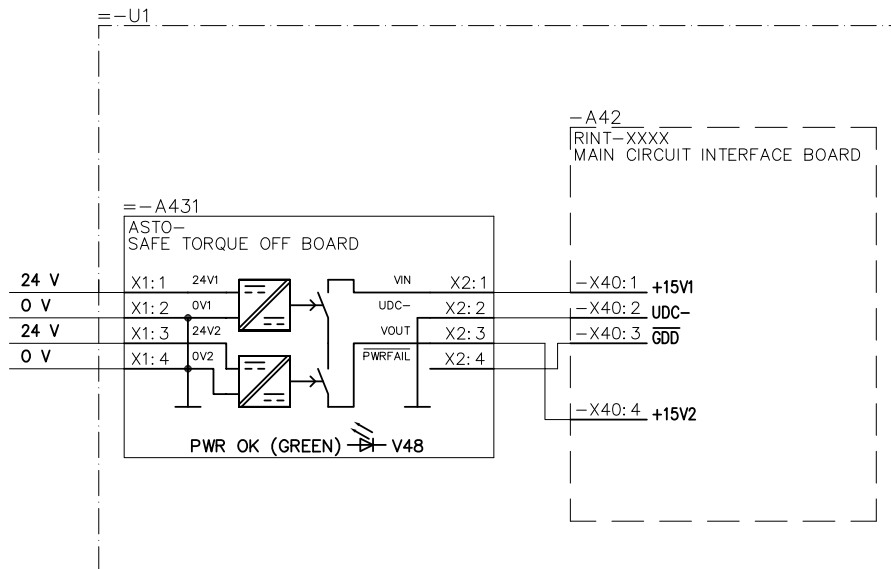

3AUA0000077408

Frame size R5i

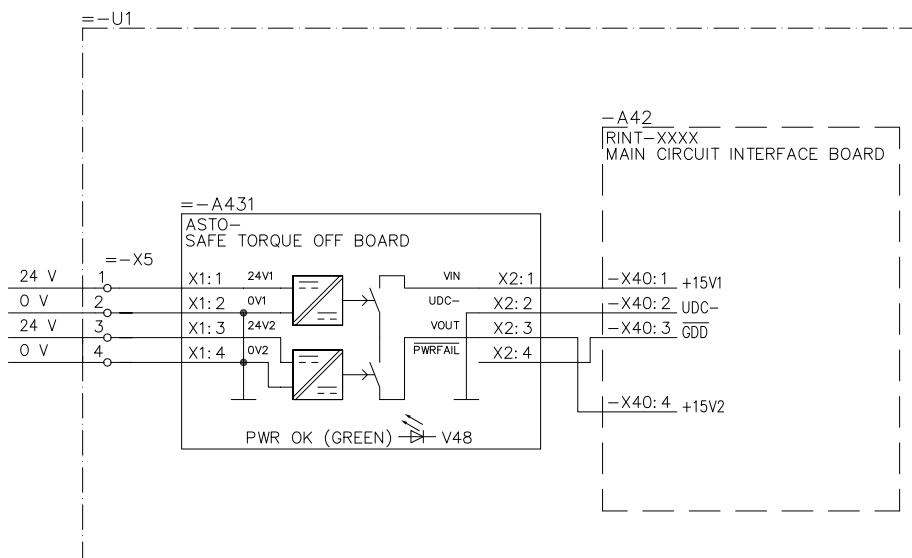

3AUA0000077456

Frame size R7i

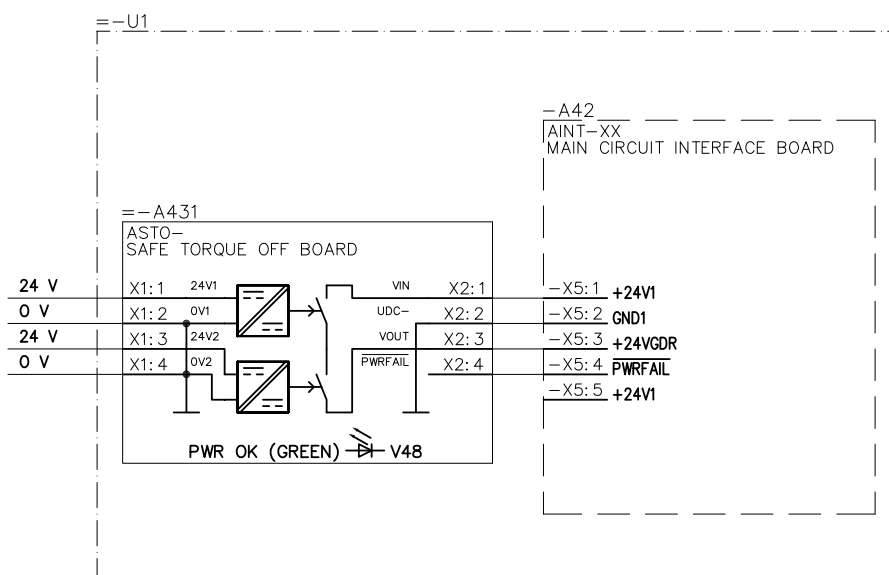

3AUA0000077458



Frame size R8i

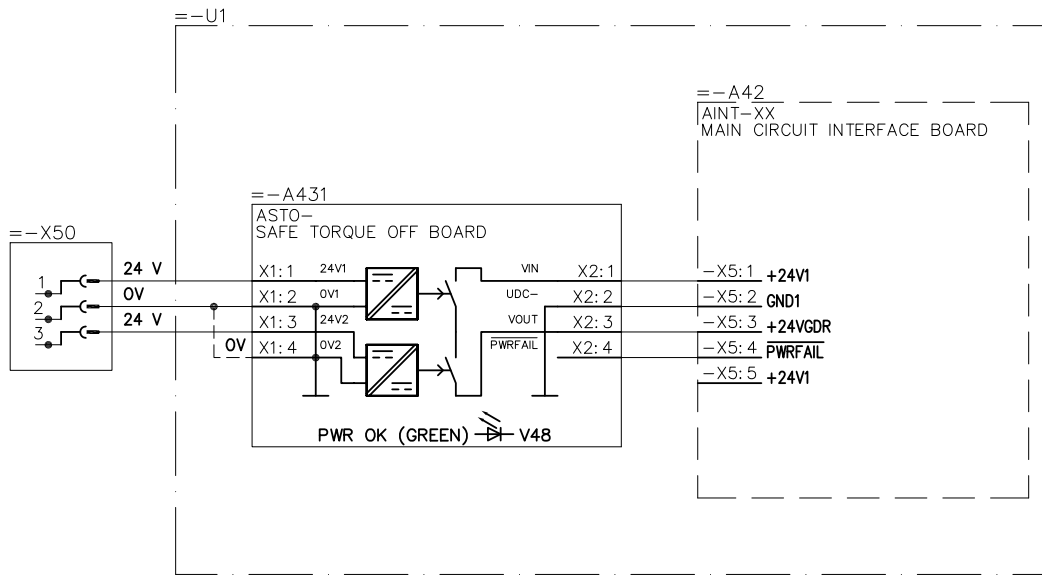

3AUA0000077457



Liquid-cooled modules of frame sizes R7i and R8i

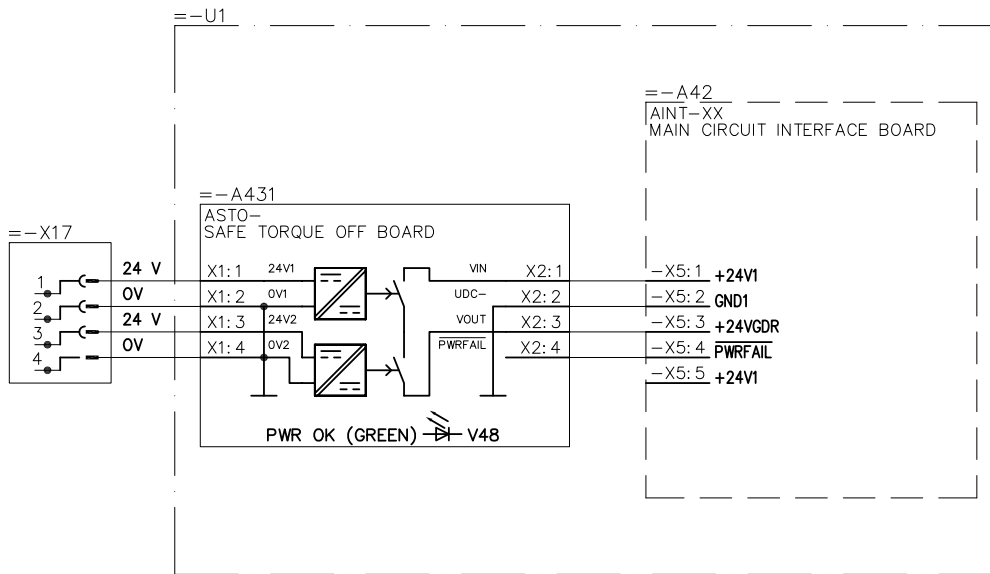

3AUA0000077142

■ With safety relay

Note: Safety relay is not included in the delivery when option code +Q967 is selected.

Frame sizes R2 to R6

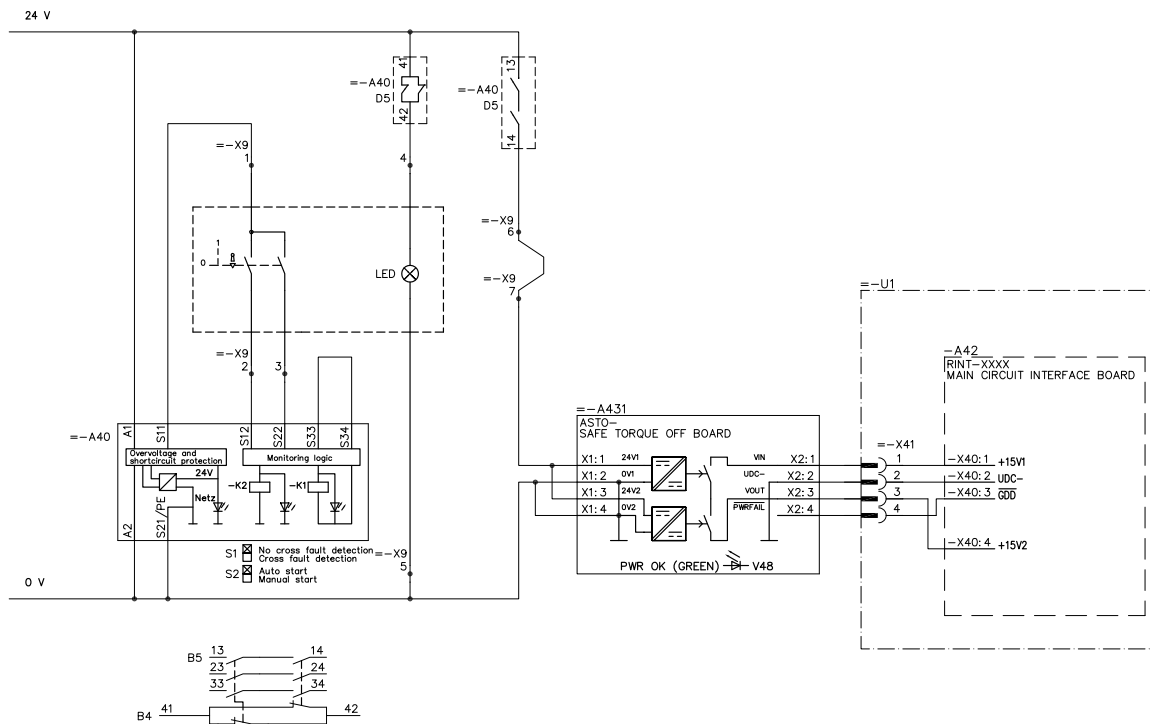

3AJA0000072271

Frame sizes R7 and R8

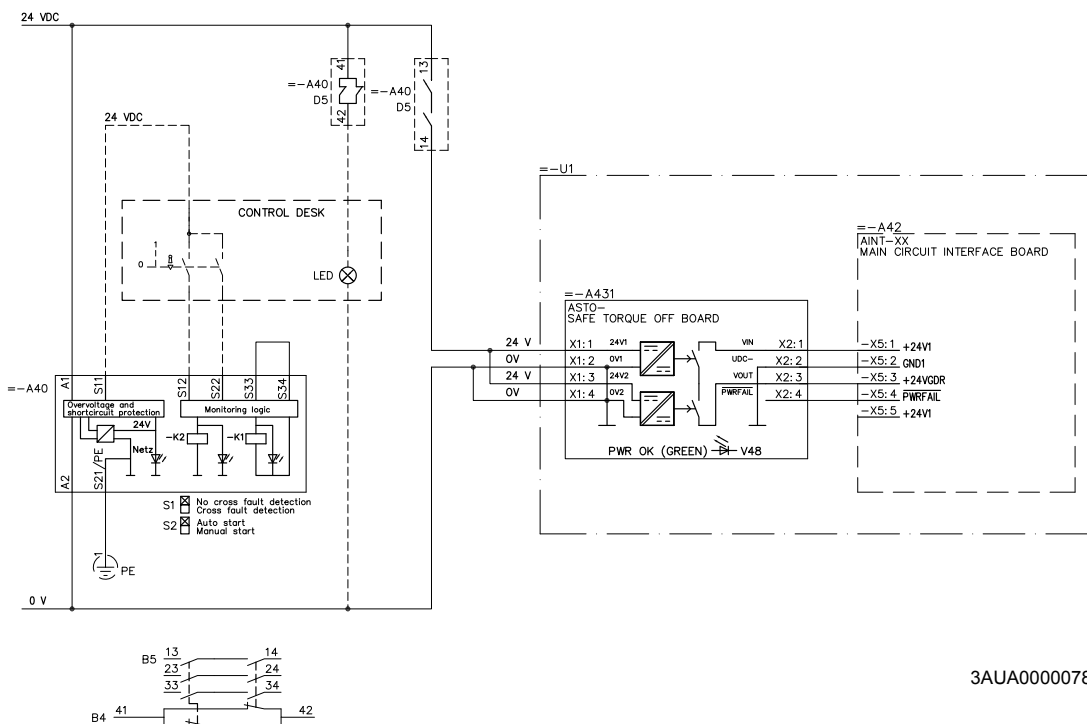

3AJA0000078208

Frame sizes R2i to R4i

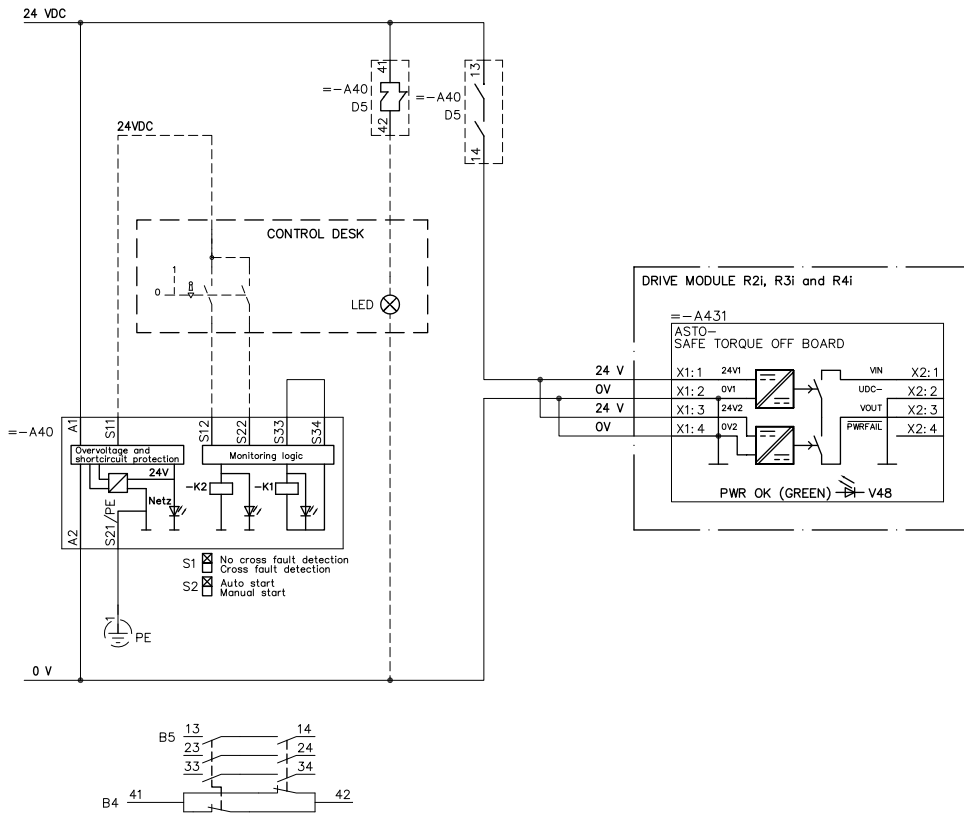

3AUA0000071122

Frame size R5i

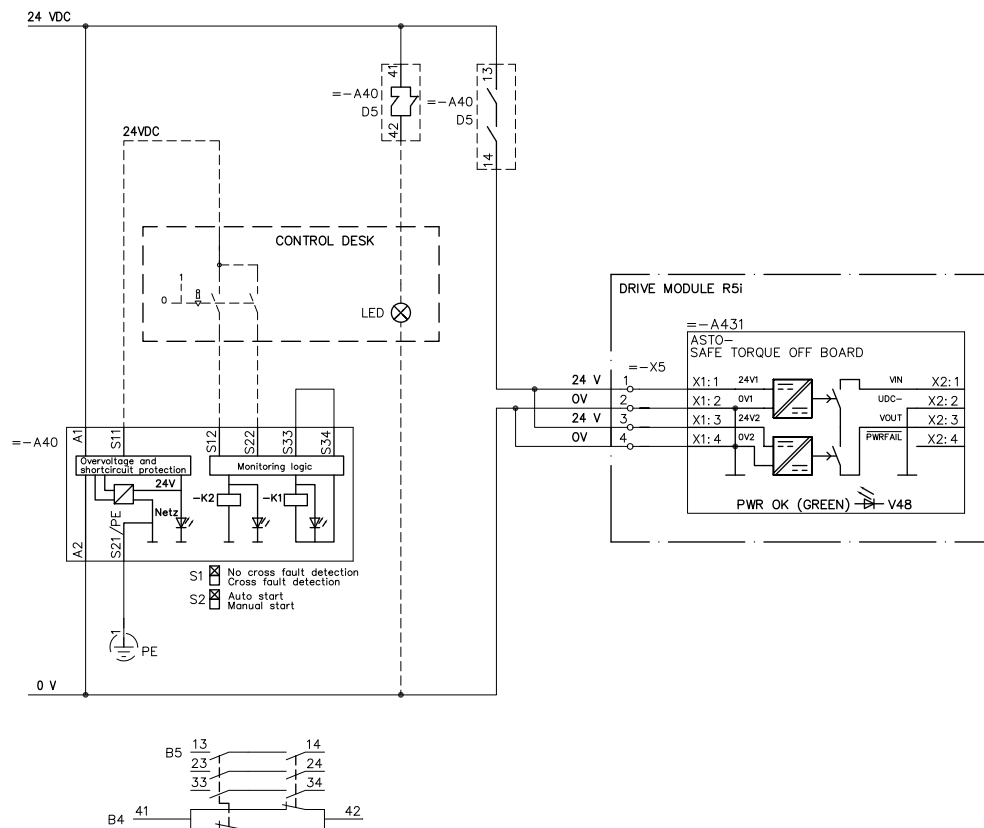

3AUA0000071141

Frame size R7i

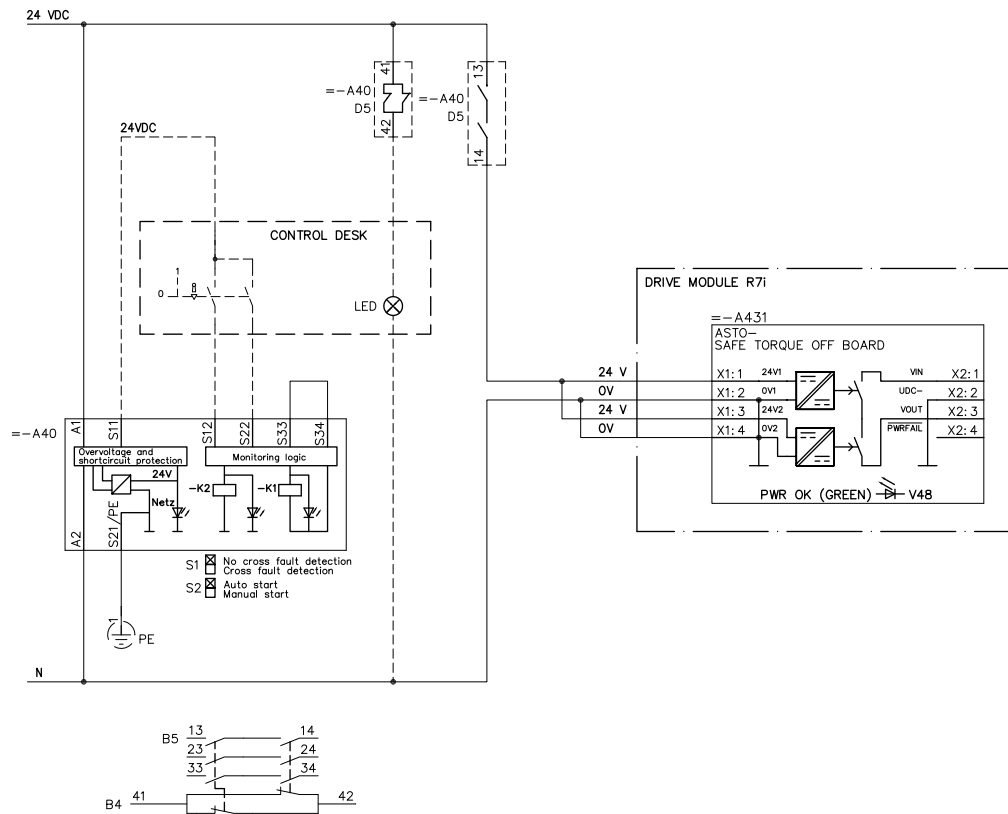

3AJUA0000071142

Frame size R8i

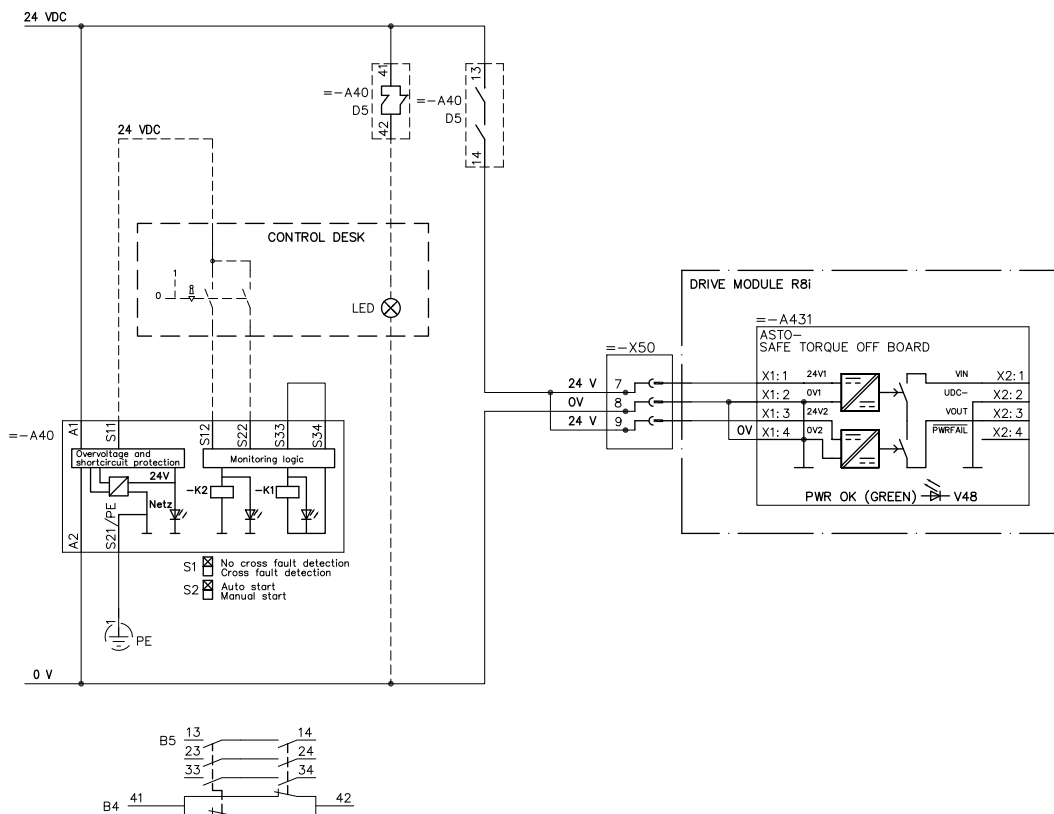

3AJUA0000071143



4

Start-up and validation

Validating the operation of a safety function

IEC 61508 and EN IEC 62061 require that the final assembler of the machine validates the operation of the safety function with an acceptance test. The acceptance tests for the standard safety functions of the drive are described in chapter *Start-up* of the drive Hardware (or User's) manual. The tests for the optional safety functions are described in the appropriate option manuals.

The acceptance test must be performed:

- at initial start-up of the safety function
- after any changes related to the safety function (wiring, components, settings, etc.)
- after any maintenance work related to the safety function.

■ Authorized person

The acceptance test of the safety function must be carried out by an authorized person with expertise and knowledge of the safety function. The test must be documented and signed by the authorized person.

■ Acceptance test reports

Signed acceptance test reports must be stored in the logbook of the machine. The report shall include documentation of start-up activities and test results, references to failure reports and resolution of failures. Any new acceptance tests performed due to changes or maintenance shall be logged into the logbook.



Start-up checklist

	Action
<input type="checkbox"/>	Ensure that the drive can be run and stopped freely during the commissioning.
<input type="checkbox"/>	Stop the drive (if running), switch the input power off and isolate the drive from the power line by a disconnecter.
<input type="checkbox"/>	Check the STO circuit connections against the circuit diagram.
<input type="checkbox"/>	Close the disconnecter and switch the power on.
<input type="checkbox"/>	Test the operation of the STO function when the motor is stopped: <ul style="list-style-type: none"> • Give a stop command for the drive (if running) and wait until the motor shaft is at standstill. • Activate the STO circuit and give a start command for the drive. • Ensure that the motor stays at standstill and the drive operates as described in section Operation of the STO function and its diagnostics function on page 9. • Deactivate the STO circuit.
<input type="checkbox"/>	Restart the drive and check that the motor runs normally.
<input type="checkbox"/>	Test the operation of the STO function when the motor is running: <ul style="list-style-type: none"> • Start the drive and ensure the motor is running. • Activate the STO circuit. • Ensure that the motor stops and the drive trips. • Reset the fault and try to start the drive. • Ensure that the motor stays at standstill and the drive operates as described in section Operation of the STO function and its diagnostics function on page 9. • Deactivate the STO circuit.
<input type="checkbox"/>	Restart the drive and check that the motor runs normally.
<input type="checkbox"/>	The STO function is safe and accepted to operate.
<input type="checkbox"/>	Document and sign the acceptance test report.



5

Maintenance, fault tracing and diagnostics

Maintenance

Include the STO operation test described in chapter [Start-up and validation](#) to the routine maintenance program of the machinery that the drive runs. If the circuit boards or wire sets are replaced inside the module, test the functioning of the safety circuit according to [Start-up checklist](#). If you detect any failure in safety functions, including STO, contact your local ABB representative.

The STO function or STO input terminals do not need any maintenance. Maintain the drive according to the instructions given in the drive hardware manual.

Warning messages generated by the drive

Warning	Cause	What to do
START INHIBI	Safe torque off function has been activated while the drive was stopped.	Close Safe torque off function switch. If the switch is closed and the warning is still active, check power supply at ASTO board input terminals. Replace ASTO board.

Fault messages generated by the drive

Fault	Cause	What to do
GD DISABLED X	ASTO board power supply of parallel-connected R8i inverter module has been switched off during run. X (1...12) refers to inverter module number.	Check Safe torque off function circuit of this module (X). Replace ASTO board of R8i inverter module.
START INHIBI	Safe torque off has been activated during motor run or motor start command has been given when Safe torque off is active.	Close Safe torque off function switch. If the switch is closed and the fault is still active, check power supply at ASTO board input terminals. Replace ASTO board.



Technical data

STO components

■ ASTO-11/21 board

Supply voltage range	+24 V DC +/- 10%
Current consumption	40 mA (20 mA/channel)
Supply cable	A single-shielded twisted pair
Maximum cable length	300 m
Conductor min. cross section	0.5 mm ² , 20 AWG

Note: Supply from semiconductor safety output with test pulse is not allowed.

ASTO board according to frame size of the module

Frame size	ASTO-11/21 board
R2i...R5i	ASTO-11
R2...R6	ASTO-11
R7i...R8i	ASTO-21
R7...R8	ASTO-21

■ STO safety relay type

General requirements	IEC 61508 and/or EN/ISO 13849-1
Example 1	Simple SIL3 approved safety relay
Type and manufacturer	DOLD LG 5925.48/60 AC/DC 24 V
Approvals	SILCL 3 according to EN 62061 and PL e according to EN ISO 13849-1
Example 2	Programmable safety logic
Type and manufacturer	PNOZ Multi M1p by Pilz
Approvals	IEC 61508, SIL3; and EN ISO 13849-1, PL e

■ Push-button to be used with emergency stop

Type	A push-button operated switch with a palm or mushroom head type. Actuators of emergency stop devices are colored red.
Example	New Elfin 020PTFASRK+020GE02

■ STO switch to be used with prevention of unexpected start-up function implemented with STO

Type	A lockable selector switch with a reliable and unambiguous indication of positions.
Example	Kraus & Naimer DH11 A291-600, FT22-V+S0V845/A11/D11

STO data related to safety standards (safety relay not included)

Data related to safety standards IEC 61508, EN 61800-5-2, EN/ISO 13849-1 and EN 62061 are listed below according to the frame sizes. Data apply to both air-cooled and liquid-cooled modules.

■ Frame size R2/R2i

SILCL, SIL	2	Category	2	Lifetime	20 years
PL	d	DC	98,35%	HFT	0
MTTF_d	462,3 years	SFF	99,62%	Proof test interval T1	20 years
PFH_d	5,81E-09 1/h (5,81 FIT)	CCF	65 points		

■ Frame size R3/R3i

SILCL, SIL	2	Category	2	Lifetime	20 years
PL	d	DC	98,49%	HFT	0
MTTF_d	465,2 years	SFF	99,66%	Proof test interval T1	20 years
PFH_d	5,06E-09 1/h (5,06 FIT)	CCF	65 points		

■ **Frame size R4/R4i**

SILCL, SIL	2	Category	2	Lifetime	20 years
PL	d	DC	96,74%	HFT	0
MTTF _d	430,4 years	SFF	99,26%	Proof test interval T1	20 years
PFH _d	15,0E-09 1/h (15,0 FIT)	CCF	65 points		

■ **Frame size R5/R5i**

SILCL, SIL	2	Category	2	Lifetime	20 years
PL	d	DC	97,34%	HFT	0
MTTF _d	442,0 years	SFF	99,39%	Proof test interval T1	20 years
PFH _d	11,5E-09 1/h (11,5 FIT)	CCF	65 points		

■ **Frame size R6**

SILCL, SIL	2	Category	2	Lifetime	20 years
PL	d	DC	98,28%	HFT	0
MTTF _d	460,8 years	SFF	99,61%	Proof test interval T1	20 years
PFH _d	6,23E-09 1/h (6,23 FIT)	CCF	65 points		

■ **Frame size R7/R7i/R8/R8i**

SILCL, SIL	2	Category	2	Lifetime	20 years
PL	d	DC	98,40%	HFT	0
MTTF _d	467,3 years	SFF	99,72%	Proof test interval T1	20 years
PFH _d	3,94E-09 1/h (3,94 FIT)	CCF	65 points		

■ **Multiples of frame size R8i**

Above values for *Frame size R7/R7i/R8/R8i* apply for the multiples of frame size R8i, except for values of MTTF_d and PFH_d. These values are listed below.

Frame size 2×R8i

MTTF _d	233,6 years
PFH _d	7,87E-09 1/h (7,87 FIT)

Frame size 3×R8i

MTTF _d	155,8 years
PFH _d	11,8E-09 1/h (11,8 FIT)

Frame size 4×R8i

MTTF _d	116,8 years
PFH _d	15,7E-09 1/h (15,7 FIT)

Frame size 5×R8i

MTTF _d	93,5 years
PFH _d	19,7E-09 1/h (19,7 FIT)

Frame size 6×R8i

MTTF _d	77,9 years
PFH _d	23,6E-09 1/h (23,6 FIT)

Frame size 7×R8i

MTTF _d	66,8 years
PFH _d	27,6E-09 1/h (27,6 FIT)

Frame size 8×R8i

MTTF _d	58,4 years
PFH _d	31,5E-09 1/h (31,5 FIT)

Frame size 9×R8i

MTTF _d	51,9 years
PFH _d	35,4E-09 1/h (35,4 FIT)

Frame size 10×R8i

MTTF _d	46,7 years
PFH _d	39,4E-09 1/h (39,4 FIT)

Frame size 11×R8i

MTTF _d	42,5 years
PFH _d	43,3E-09 1/h (43,3 FIT)

Frame size 12×R8i

MTTF _d	38,9 years
PFH _d	47,3E-09 1/h (47,3 FIT)

■ Abbreviations

Abbreviation	Reference	Description
ASTO		Safe torque off board
CCF	EN/ISO 13849-1	Common Cause Failure (%)
DC	EN/ISO 13849-1	Diagnostic Coverage
FIT	IEC 61508	Failure In Time: 1E-9 hours
HFT	IEC 61508	Hardware Fault Tolerance
MTTF _d	EN/ISO 13849-1	Mean Time To dangerous Failure: (The total number of life units) / (the number of dangerous, undetected failures) during a particular measurement interval under stated conditions
PFH _d	IEC 61508	Probability of Dangerous Failures per Hour
PL	EN/ISO 13849-1	Performance Level: Corresponds SIL, Levels a-e
SFF	IEC 61508	Safe Failure Fraction (%)
SIL	IEC 61508	Safety Integrity Level
STO	EN 61800-5-2	Safe torque off

TÜV certificate



Certificate

TÜV NORD SysTec GmbH & Co. KG hereby certifies

ABB Oy
Hiomotie 13
FI-00381 Helsinki
Finland

for the realisation of the functions “Safe Torque Off - STO”
and “Safe Stop 1 – SS1” in the ABB product series

Type ACS800 frame R2(i)-R8(i)

the compliance with the requirements listed in the following standards

- IEC 61508 part 1:1998; part 2:2000; SIL 2
- IEC 61800-5-2:2007; SIL 2
- ISO 13849-1:2008; PL d (category 2)
- IEC 62061:2005; SIL_{CL2}

based on report No. SLA-0232/2008TB1 in the valid version.

This certificate entitles the holder to use the mark:

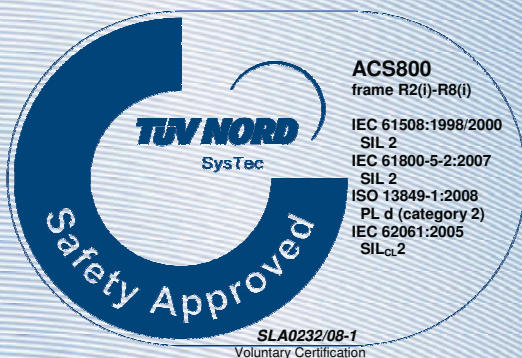

Expiry date: 2015-02-17
Certification No. : SLA-0232/08-1
Reference No. : G.SCC.DL.03.004.08.SLA
Augsburg, 2010-02-17

TÜV NORD SysTec GmbH & Co. KG
Branch South
Halderstraße 27
86150 Augsburg

Dr. Immanuel Höfer

10

Further information

Product and service inquiries

Address any inquiries about the product to your local ABB representative, quoting the type designation and serial number of the unit in question. A listing of ABB sales, support and service contacts can be found by navigating to www.abb.com/drives and selecting *Sales, Support and Service network*.

Product training

For information on ABB product training, navigate to www.abb.com/drives and select *Training courses*.

Providing feedback on ABB Drives manuals

Your comments on our manuals are welcome. Go to www.abb.com/drives and select *Document Library – Manuals feedback form (LV AC drives)*.

Document library on the Internet

You can find manuals and other product documents in PDF format on the Internet. Go to www.abb.com/drives and select *Document Library*. You can browse the library or enter selection criteria, for example a document code, in the search field.

Contact us

ABB Oy

Drives
P.O. Box 184
FI-00381 HELSINKI
FINLAND
Telephone +358 10 22 11
Fax +358 10 22 22681
www.abb.com/drives

ABB Inc.

Automation Technologies
Drives & Motors
16250 West Glendale Drive
New Berlin, WI 53151
USA
Telephone 262 785-3200
1-800-HELP-365
Fax 262 780-5135
www.abb.com/drives

ABB Beijing Drive Systems Co. Ltd.

No. 1, Block D, A-10 Jiuxianqiao Beilu
Chaoyang District
Beijing, P.R. China, 100015
Telephone +86 10 5821 7788
Fax +86 10 5821 7618
www.abb.com/drives

3AJUA0000063373 Rev B EN 2010-05-14